

# T-BERD®/MTS-4000 Platform

## Metro-PON (MP) OTDR Module



### Key Features

- First-to-market handheld OTDR module with more than 40 dB dynamic range and very high resolution
- PON Optimized for testing up to 1x128 splitters with 1310/1490/1550/1625/1650 nm wavelengths
- Single port configuration enables standard and in-service testing
- Instantaneous traffic detection when connecting live fiber
- Integrated source and power meter under OTDR port
- Automated bend detection

### Applications

- Used to install, maintain, and troubleshoot Metro, Access, and FTTH networks
- Provides a fiber characterization solution for current and future Access/FTTH networks (Ethernet, PON, and NG-PON)

Testing Metro, cable TV (CATV), and fiber-to-the home (FTTH) networks with larger crews calls for using handheld, cost-effective, and versatile test equipment with the highest performance capability. The JDSU Metro-PON (MP) OTDR Module meets the challenges of commissioning a complete metro ring, troubleshooting a bend in a distribution frame, and qualifying high-port-count optical splitters up to a 128 splitting ratio.

The MP OTDR Module, part of the T-BERD/MTS-4000 product family, offers a rugged, battery-operated handheld test solution. Its large display combined with a comprehensive user interface makes it the ideal OTDR for any test scenario.



### Performance Versatility for Backbone, Metro, Access, and CATV Networks

The MP OTDR provides field technicians with a broad range of testing tools for the installation, maintenance, and troubleshooting of Backbone, Metro, and Access

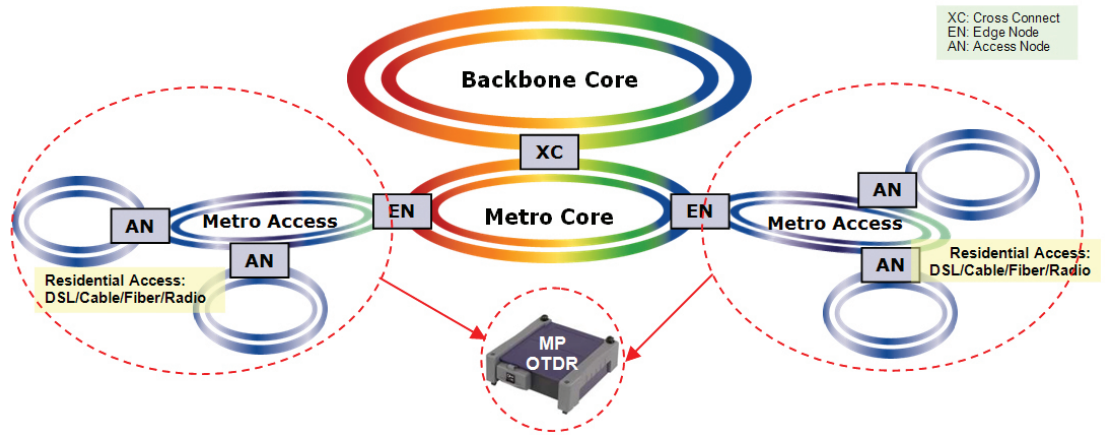

### Provides Optimum Performance for Metro, Access/FTTH, and CATV RfOg Applications

Metro-Access networks enable multiservice delivery and handoff to larger Metro Core networks. Because distances, losses, and fiber-counts vary significantly, the ideal test solution will outperform in any test scenario. The MP OTDR module provides the performance that fiber installers and service providers need to fulfill these test challenges. The combination of fast acquisition time, high resolution (<0.8 m event dead zone), and a 41 dB dynamic range makes the MP OTDR module an ideal tool for:

- detailed events commissioning of point-to-point fiber links to characterize splices, connectors, and fiber sections
- OTDR acceptance testing with the addition of end-to-end loss and optical return loss (ORL) measurements
- troubleshooting any fault in the network.

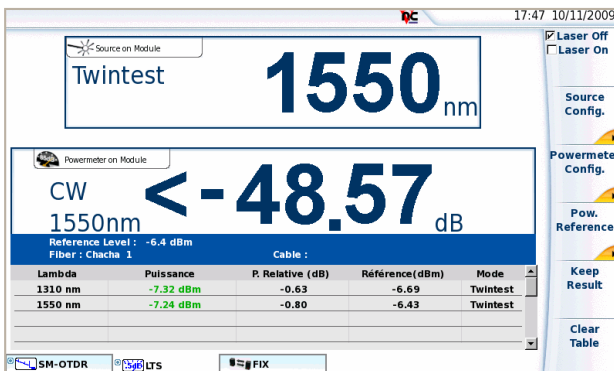

Figure 1. Loss test set feature (light source and power meter)

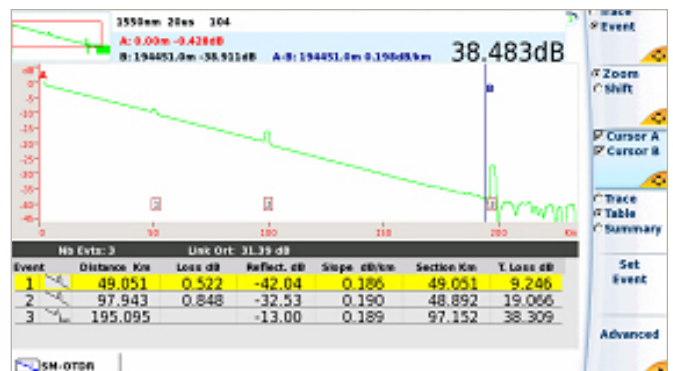

Figure 2. Results of 200 km link tested with the MP OTDR

**The Ideal Test Tool for Access/FTTH and CATV Applications (G-PON, E-PON, NG-PON, RFoG)**

The Access network extends from the central office or headend out to individual businesses or homes using various technologies such as point-to-point Ethernet or passive optical networks (PON). It typically spans a few meters to several kilometers or miles. The measurement of very short distances associated with high point losses, due to passive splitters, brings new testing challenges by compromising dynamic range and resolution. The MP OTDR Module is “PON-optimized” as a result of:

- improved dynamic range at short pulses (up to 300 ns for optimized resolution and dead zone) to qualify PON systems up to 1x128 splitting ratio
- sharp resolution to precisely identify closely spaced events and near-end faults
- automatic detection of splitters with clear identification on the table of results
- in-service filtered wavelengths (1625 or 1650 nm) for troubleshooting a faulty customer without disturbing live traffic.

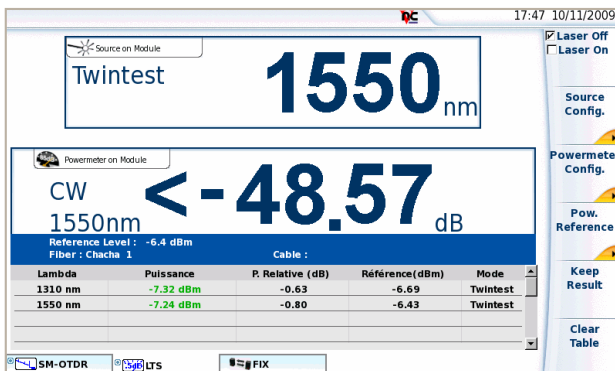
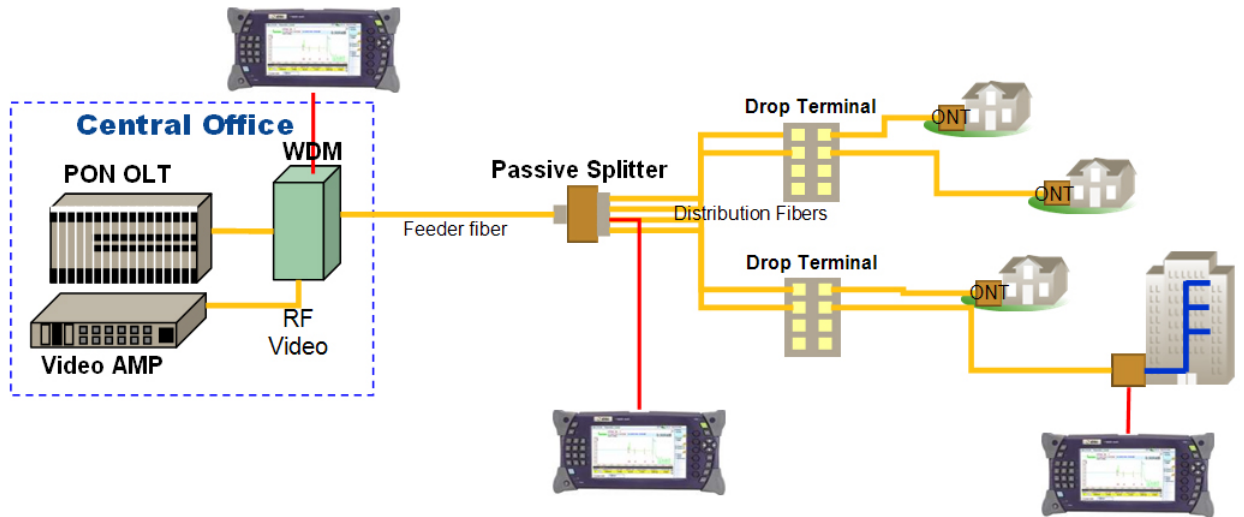

Figure 3. 1x2 then 1x8 then 1x8 (total 1x128) PON test from ONT Automatic detection of splitters

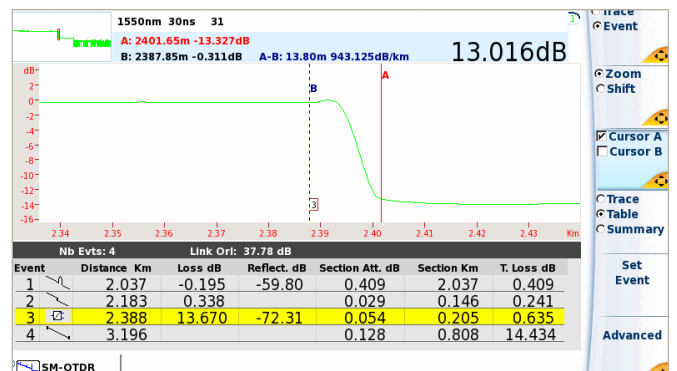

Figure 4. 1x16 (13 dB) splitter with 13.8m dead zone for optimized analysis after splitter

## Enhanced User Interface for Improved Productivity

### Live Traffic Detection

The automatic traffic detection capability enables users to verify the presence of a signal immediately after connecting the fiber under test to the OTDR port, which reduces instances of conducting unwanted measurements on live fiber. In one direction, the signal that the OTDR emits could affect the optical transmitter. In the other direction, the transmission signal could affect the measurement quality and perhaps damage the OTDR receiver. To avoid these risks, the OTDR displays an on-screen warning when detecting a signal or modulation prompting the technician to confirm or cancel the measurement.

### The Right Test Mode for the Right Job

The MP OTDR features four operating modes based on technicians' requirements:

- The Fault Locator boosts productivity in the field with a fully automatic, one-touch operating mode that requires no settings and provides the link's end-of-fiber location, the total loss, and ORL.
- The Quick-link Test combines automatic acquisition setup with detailed trace analysis offering unmatched intuitiveness for novice or intermittent users.
- The Construction mode offers a high-level trace analysis, making the MP OTDR a powerful instrument for fiber commissioning.
- The fast real-time mode (0.1 s) helps to achieve optimal setups by providing instant measurement values and feedback on changes to technicians with direct access to the acquisition parameters in the result view. This mode also offers an auto Zoom to End key that is useful when adjusting connectors or splicing.

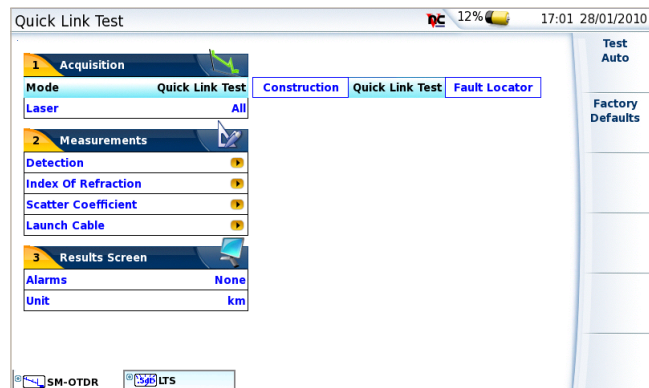

Figure 5. OTDR setup page with three test modes

### Initial Fiber Connection Check

At the beginning of the acquisition, a bar graph illustrates of the connection quality between the OTDR and the link under test or front connector to ensure field technicians perform measurements under optimal conditions. At the end of the acquisition, the loss and the reflectance of this connector can also be shown in the table of results. If the connection is bad, the optional USB scope with Pass/Fail analysis will identify the issue.

### Macro-Bend Detection

The dual wavelength testing capability enables automatically locating and displaying macro-bends to shorten analysis time, especially when troubleshooting a fiber link.

Summary Table			
Laser nm	T. Loss dB	Total Ori dB	T.Length m
1550	5.759	< -9.00	1294.13
1625		< -9.00	

Bend Table	
Bend dB	Distance m
1	0.652 1271.88
2	0.497 884.42

Figure 6. Results summary page showing bend detection

## Innovative and Bold Test Function Implementation

### In-Service Maintenance

The MP OTDR module supports in-service PON measurements per the ITU-T L.41 recommendation on “Maintenance Wavelength on Fibers Carrying Signals” that enables in-service measurements using out-of-band wavelengths (1625 or 1650 nm), which avoids interference with the optical link or central office laser transmitter performance. The MP OTDR module features both filtered 1625 and 1650 nm out-of-band wavelengths (where traffic is not distributed) allowing for rejection of unwanted signals (1310, 1490, and 1550 nm) that could disturb the OTDR measurement.

Traditional 1310/1550 nm and filtered 1625 nm wavelengths are coupled into one single OTDR port allowing 1310/1550/1625 nm fiber qualification and avoiding multiple connections/disconnections as well as in-service error-free testing.

### Integrated Loss Test Set

The OTDR port operates as a standard laser source to provide continuous wave and standard modulations and also integrates an optional power meter. These two functions enable a full-featured loss test set, reducing the cost of goods, the number of tools to carry in the field, and the time for testing fiber optic networks.

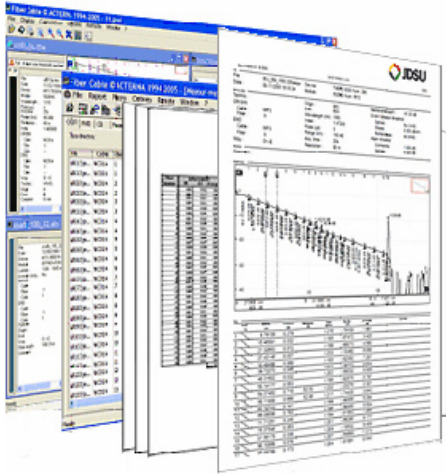

### Error-Free Professional Report

The T-BERD/MTS-4000 platform features a PDF writer and reader to generate and recall PDF test reports directly from the built-in explorer without using an offline software program.

For more integrated reports, a PC-based software application within a true Microsoft Windows environment offers detailed generation of professional OTDR trace reports.

- Proof of performance
- Fully customizable report
- Dedicated tables for each test result
- Out-of-range value summary with Pass/Fail indicators
- Analysis of macro-bends



Figure 7. OTDR setup page with three test modes

## Specifications

### General (Typical at 25°C)

Weight	0.35 kg (0.77 lb)
Dimensions (w × h × d)	128 × 134 × 40 mm (5.04 × 5.28 × 1.58 in)

### Optical interfaces

Applicable fiber	SMF 9/125 μm
Interchangeable optical connectors	FC, SC, DIN, LC (PC or APC) and ST (PC) FC, SC, DIN, LC (PC or APC) and ST (PC)

### Technical Characteristics

Laser safety class (21 CFR)	Class 1
Distance units	Kilometers, feet, and miles
Group index range	1.30000 to 1.70000 in 0.00001 steps

Number of data points	Up to 256,000 data points
Distance measurement	Automatic or dual cursor
Display range	0.5 to 260 km
Cursor resolution	1 cm
Sampling resolution	4 cm
Accuracy	±1 m ±sampling resolution ±1.10 <sup>-5</sup> x distance (Excluding group index uncertainties)

### Attenuation measurement

Automatic, manual, 2-point, 5-point, and LSA	
Display range	1.25 to 55 dB
Display resolution	0.001 dB
Cursor resolution	0.001 dB
Linearity	±0.03 dB/dB
Threshold	0.01 to 5.99 dB in 0.01 dB steps

### Reflectance/ORL Measurements

Reflectance accuracy	±2 dB
Display resolution	0.01 dB
Threshold	-11 to -99 dB in 1 dB steps

### Broadband Power Meter (Optional)

Power level range	0 to -55 dBm
Measurement wavelengths	1310, 1490, 1550, 1625, and 1650 nm
Calibrated wavelengths	1310, 1490, 1550, 1625, and 1650 nm
Measurement accuracy	±0.5 dB

### OTDR Module (Typical at 25°C)

These are standard specifications, representing only a selection of the JDSU offerings. For specific requirements, please contact your local JDSU representative.

Central Wavelength <sup>1</sup>	Pulse Width	RMS Dynamic Range <sup>2</sup>	Event Dead Zone <sup>3</sup>	Attenuation Dead Zone <sup>4</sup>
1310 ± 20 nm	3 ns to 20 μs	42 dB	0.8 m	4 m
1490 ± 20 nm	3 ns to 20 μs	40 dB		
1550 ± 20 nm	3 ns to 20 μs	40 dB		
1625 ± 10 nm	3 ns to 20 μs	40 dB		
1650 ± 20 nm	3 ns to 20 μs	40 dB		

(1) Laser at 25°C and measured at 10 μs.

(2) The one-way difference between the extrapolated backscattering level at the start of the fiber and the RMS noise level, after 3 minutes averaging.

(3) Measured at ±1.5 dB down from the peak of an unsaturated reflective event.

(4) Measured at 1310 nm and ±0.5 dB from the linear regression using a FC/PC-type reflectance.

## Ordering Information

Part Number	Description
E4126MP	Metro PON 1310/1550 nm OTDR Module
E4138MP49	Metro PON 1310/1490/1550 nm OTDR Module
E4136MP	Metro PON 1310/1550/1625 nm OTDR Module
E4136RMP	Metro PON 1310/1550 and Filtered 1625 nm OTDR Module
E4118RMP65	Metro PON Filtered 1650 nm OTDR Module
<b>Universal optical connectors</b>	
EUNIPCF, EUNIPCSC, EUNIPCST, EUNIPCDIN, EUNIPCLC	Straight connectors
EUNIAPCF, EUNIAPCSC, EUNIAPCDIN, EUNIAPCLC	8° angled connectors

For more information on the T-BERD/MTS-4000 test platform, please refer to the separate data sheet and brochure.

**Test & Measurement Regional Sales**

<b>NORTH AMERICA</b> TEL: 1 866 228 3762 FAX: +1 301 353 9216	<b>LATIN AMERICA</b> TEL: +1 954 688 5660 FAX: +1 954 345 4668	<b>ASIA PACIFIC</b> TEL: +852 2892 0990 FAX: +852 2892 0770	<b>EMEA</b> TEL: +49 7121 86 2222 FAX: +49 7121 86 1222	<b>WEBSITE: <a href="http://www.jdsu.com/test">www.jdsu.com/test</a></b>
---	--	---	---	--