



BRIDG-IT DOFR 8000

Dual Optical Forward Receiver

Features

- ▶ Simple installation (plug-in module, hot swappable)
- ▶ Dual optical input, dual RF output
- ▶ Wavelength 1290 up to 1610 nm
- ▶ Operating up to 862 MHz
- ▶ Adjustable RF output level
- ▶ Remote monitoring via RS-485 communication standard
- ▶ Front panel test points
- ▶ Mountable in the 3 unit high UPL 8000 19" rack
- ▶ Front controls
- ▶ Rear connections
- ▶ Automatic or Manual Gain Control (AGC / MGC)
- ▶ Pilot AGC (in combination with e.g. OFT 8000) to provide efficient overall compensation



Description

The M-TEC DOFR 8000 dual optical forward receiver is a 10TE wide plug-in module, which can be installed in the M-TEC UPL 8000 19" rack. It has been designed for simplicity of installation and operation.

This high channel capacity module features two 1290 to 1610 nm receivers with a pass band of 45 - 862 MHz. The DOFR 8000 receives both single optical input signals through a low reflection optical connector, and internally converts the signals back into RF signals.

A high performance GaAs based amplifier then amplifies the RF signals to the desired output level. Typical characteristics for GaAs amplifiers are the low noise levels, high-class distortion levels, and excellent flatness.

The module is equipped with a DC voltage test point to monitor the optical input level. This way a digital voltmeter and a standard field strength meter suffice for testing purposes. No advanced and/or expensive optical test equipment is necessary. The voltage reading in volts equals the optical power in mW.

The RF output level can be monitored via the -20 dB test point. Two front panel pushbuttons enable adjustment of the RF output level.

Remote monitoring and controlling of the module is possible via the 9-pin SUB-D data link and RS-485 communication standard. All settings can be remotely checked and changed. Abnormal operating condition alerts can automatically be fed back to the operator.

Block Diagram

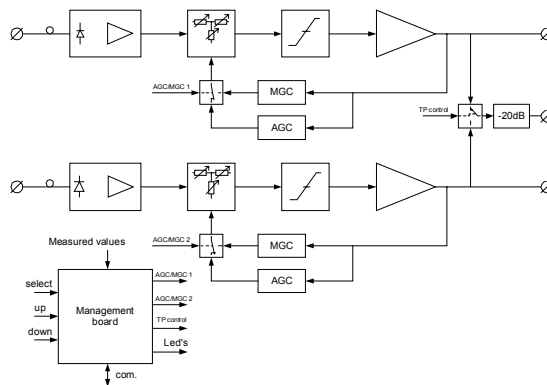

Order Information

MT	DOFR	8	-	W	XX	Y	ZZ
		# Inputs			Connector	Output Level (1)	Options
		1 = single			FU = FC/UPC	H = High (44 dBmV)	00 = none
		2 = dual			SU = SC/UPC	L = Low (40 dBmV)	
					F8 = FC/APC8°		
					F9 = FC/APC9°		
					S8 = SC/APC8°		
					S9 = SC/APC9°		
					LC = LC/UPC		
					MU = MU		
					E2 = E2000		

Notes:

(1) Output level @ 0 dBm / 4.5%

Front Panel User Interface

LED indicators	
A	Channel A selected = Red
B	Channel B selected = Red
AGC / MGC	AGC selected = Green
	MGC selected = Red
RF OUT	RF OUT adjustment enabled = Red
Controls	
AGC / MGC	AGC or MGC selection button
SELECT	Channel A or B selection pushbutton
UP	RF output level UP pushbutton
DOWN	RF output level DOWN pushbutton
Test Points	
Optical signal level	1 V/mW
RF output test point level	-20 dB

Specifications

Optical Input		AGC / MGC	
Wavelength	1290-1610 nm	AGC via (4)	Forward Transmitter Pilot
Detector	PIN diode	AGC pilot frequency	43.4 MHz
Max. optical input power	0 dBm (1 mW)	AGC / MGC step	0.5 dB
Min. optical input power	-3 dBm	AGC adjustment range	-11 dB to +3 dB
Fiber type	monomode 9/125 μm	MGC adjustment range	-10 dB to 0 dB
Return loss	≥ 45 dB	Power Requirements	
Connector type (2)	FC/APC8°	DC voltage	24 V
RF Output		Max. DC current	850 mA
Bandwidth	45-862 MHz	Max. power consumption	20.5 W
Flatness	± 1 dB	Powering via	9-pin SUB-D
Output level (3)	30 to 44 dBmV	Environmental	
Impedance	75 ohm	Operating temperature	-10 to +50°C (14 to 122°F)
Return loss	≥ 16 dB	Mechanical	
CSO (0 dBm input)	≤ -60 dB	Size (5)	128 mm * 51 mm * 370 mm
CTB (0 dBm input)	≤ -60 dB	Weight	1400 g
Isolation between channels	≥ 60 dB	Monitoring	
Connector type	F	Communication standard	RS-485

Notes:

(2) Standard FC/APC8°, other connector types available on demand.

(3) This output level can be reached over the specified optical input level range with 4.5% OMI.

(4) Pilot from forward transmitter (e.g. OFT 8000).

(5) Size = height * width * depth