



BRIDG-IT MORR 8000

Multiple Optical Reverse Receiver

Features

- ▶ Simple installation (plug-in module, hot swappable)
- ▶ Quadruple optical input, quadruple RF output
- ▶ Support for 4 independent 5 to 305 MHz upstream paths
- ▶ Compatible with RF destacker 4 x 5.65 MHz
- ▶ Wavelength 1200 up to 1610 nm
- ▶ Adjustable RF output level
- ▶ Remote monitoring via RS-485 communication standard
- ▶ Front panel test point
- ▶ Mountable in the 3 unit high UPL 8000 19" rack
- ▶ Front controls
- ▶ Rear connections
- ▶ Automatic or Manual Gain Control (AGC / MGC)
- ▶ Pilot AGC (in combination with e.g. MORT 8000) to provide efficient overall compensation



Description

The M-TEC MORR 8000 multiple optical reverse receiver is a 10TE wide plug-in module, which can be installed in the M-TEC UPL 8000 19" rack. It has been designed for simplicity of installation and operation.

This high channel capacity module features up to four 1200 to 1610 nm receivers with a pass band of 5 - 305 MHz. The MORR 8000 receives all single optical input signals through a low reflection optical connector, and internally converts the signals back into RF signals.

A high performance GaAs based amplifier then amplifies the RF signals to the desired output level. Typical characteristics for GaAs amplifiers are the low noise levels, high-class distortion levels, and excellent flatness.

The RF output level can be monitored via the -20 dB test point. Two front panel pushbuttons enable adjustment of the RF output level.

Remote monitoring and controlling of the module is possible via the 9-pin SUB-D data link and RS-485 communication standard. All settings can be remotely checked and changed. Abnormal operating condition alerts can automatically be fed back to the operator.

Block Diagram

Please refer to the final page of this data sheet.

Order Information

MT	MORR	8	-	W	XX	Y	ZZ
				# Inputs	Connector	Optical Options	Options
				1 = 1 input	S8 = SC/APC8°	0 = none	00 = none
				2 = 2 inputs			
				3 = 3 inputs			
				4 = 4 inputs			

Front Panel User Interface

LED indicators	
λ1	Channel λ1 selected = Red
λ2	Channel λ2 selected = Red
λ3	Channel λ3 selected = Red
λ4	Channel λ4 selected = Red
AGC / MGC	AGC selected = Green MGC selected = Red
RF OUT	RF OUT adjustment enabled = Red
Controls	
AGC / MGC	AGC or MGC selection button
SELECT	Channel λ1, λ2, λ3 or λ4 selection pushbutton
UP	RF output level UP pushbutton
DOWN	RF output level DOWN pushbutton
Test Points	
RF output test point level	-20 dB

Specifications

Optical Input		AGC / MGC	
Wavelength	1200-1610 nm	AGC via (4)	Reverse Transmitter Pilot
Detector	PIN diode	AGC pilot frequency	4.5 MHz
Max. optical input power	0 dBm (1 mW)	AGC / MGC step	0.5 dB
Min. optical input power	-10 dBm	AGC adjustment range	-3 dB to +3 dB
Fiber type	monomode 9/125 μm	MGC adjustment range	-20 dB to 0 dB
Return loss	≥ 40 dB	Power Requirements	
Connector type	SC/APC8°	DC voltage	24 V
RF Output		Max. DC current	450 mA
Bandwidth	5-305 MHz	Max. power consumption	11 W
Flatness	± 1 dB	Powering via	9-pin SUB-D
Output level (1)	24 to 30 dBmV	Environmental	
Impedance	75 ohm	Operating temperature	-10 to +50°C (14 to 122°F)
Return loss	≥ 20 dB	Mechanical	
Second order (2)	≤ -58 dB	Size (5)	128 mm * 51 mm * 370 mm
Third order (3)	≤ -70 dB	Weight	1265 g
Channel isolation 5-65 MHz	≥ 60 dB	Monitoring	
Channel isolation 65-305 MHz	≥ 50 dB	Communication standard	RS-485
Connector type	F		

Notes:

- (1) This output level can be reached over the specified optical input level range with 2.5% OMI.
- (2) Two laser test, each laser with 10% modulation index. Measured at $f_1 - f_2 = 7$ MHz, with $P_1 + P_2 = -3$ dBm.
- (3) Two laser test, each laser with 10% modulation index. Measured at $2x f_1 - f_2 = 28$ MHz, with $P_1 + P_2 = -3$ dBm.
- (4) Pilot from reverse transmitter (e.g. MORT 8000)
- (5) Size = height * width * depth



BRIDG-IT MORR 8000

Multiple Optical Reverse Receiver



Block Diagram

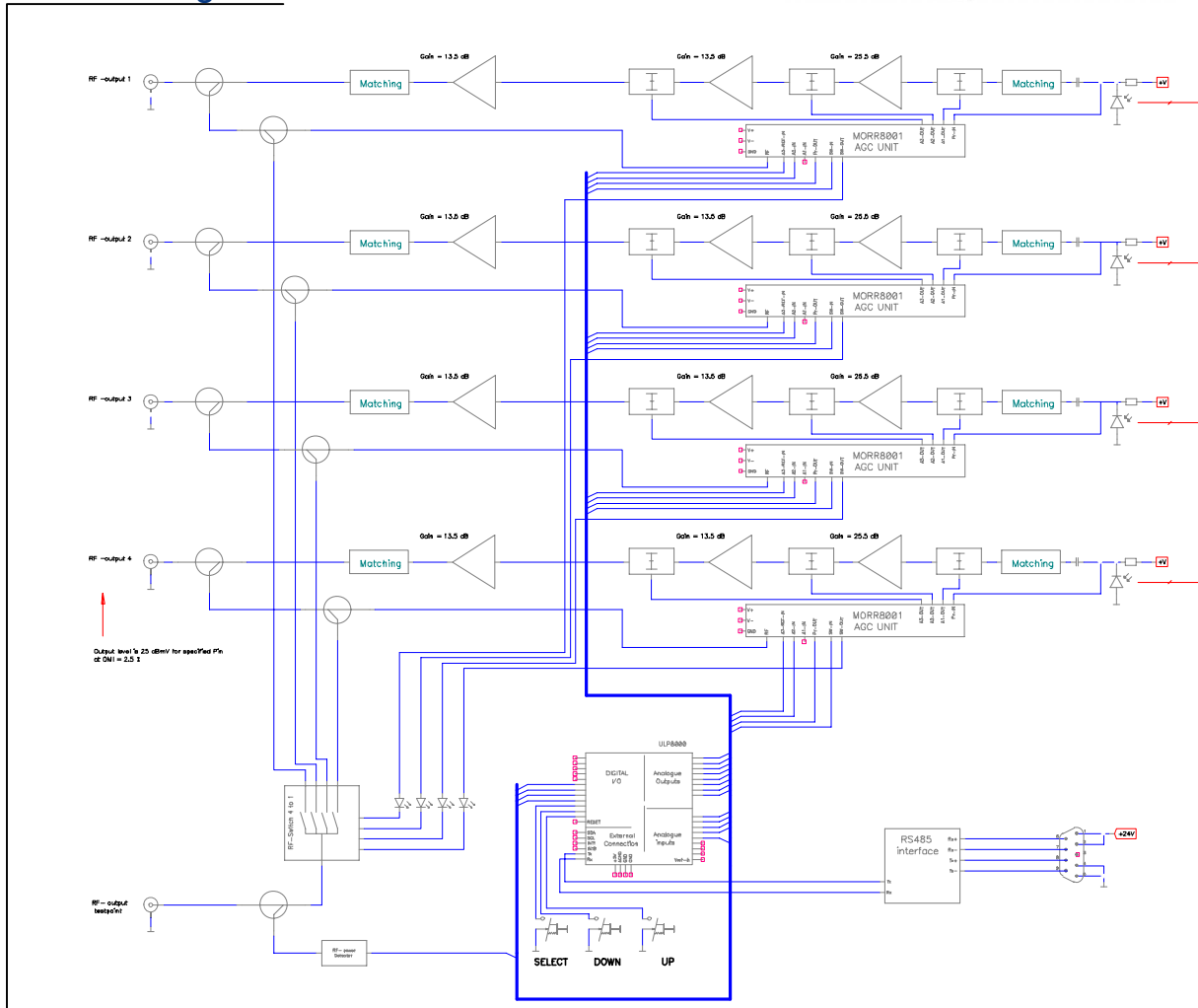

Diagrams

