



BRIDG-IT OFT 3000

Optical Forward Transmitter

Features

- ▶ Single RF input, single optical output
- ▶ Operating up to 862 MHz
- ▶ 1310 nm operation
- ▶ Temperature controlled laser
- ▶ Adjustable OMI (Optical Modulation Index) level
- ▶ Remote monitoring via RS-485 communication standard
- ▶ Front panel test point
- ▶ Mounted in the 1 unit high URU 3000 19" rack (fixed)
- ▶ Front controls
- ▶ Rear connections
- ▶ Automatic or Manual Gain Control (AGC / MGC)
- ▶ Built-in pilot enables AGC controlled links, in combination with e.g. DOFR 3000
- ▶ Broadband detection circuit for stable OMI when loads change

Description

The M-TEC OFT 3000 optical forward transmitter is a module that can be integrated in the M-TEC URU 3000 19" rack. It has been designed for simplicity of operation.

This high channel capacity module features low noise and low distortion RF driver circuits, a high performance DFB laser diode, and pre-distortion electronics. The received RF input is optimized for further conversion by means of the RF drivers. The pre-distortion electronics compensate for the non-linearity of the DFB laser diode. The laser driver circuits bias the laser diode to its proper optical operating level, while stability is guaranteed by automatic temperature and power control circuits.

The DFB laser module includes an integrated opto-isolator to reduce the optical power reflected back into the laser, preventing increased laser noise.

The implemented design as described above, ensures the highest carrier-to-noise ratio (CNR) and minimal distortion towards the user.

The RF input level can be monitored via the RF input at laser test point. Two front panel pushbuttons enable adjustment of the OMI level.

Remote monitoring and controlling of the module is possible via the 9-pin SUB-D data link and RS-485 communication standard. All settings can be remotely checked and changed. Abnormal operating condition alerts can automatically be fed back to the operator.

Block Diagram

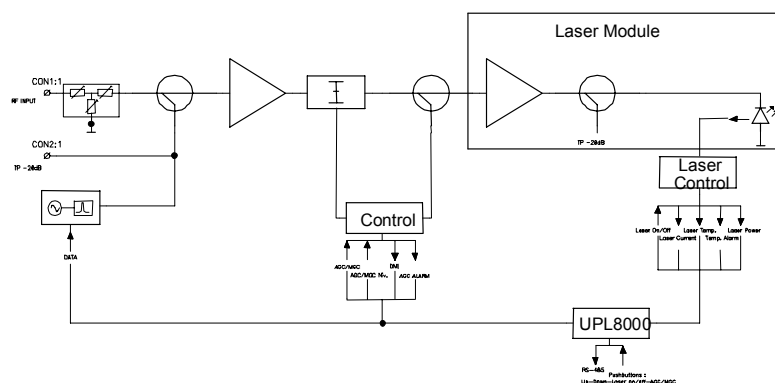

Order Information

Contact us

Front Panel User Interface

LED indicators	
T° ALARM	Laser temperature out of range = Red
INPUT LEVEL LOW (1)	RF input power too low = Red
INPUT LEVEL HIGH (2)	RF input power too high = Red
AGC / MGC	AGC selected = Green / MGC selected = Red
LASER ON / OFF	Laser ON = Green / Laser OFF = Red
OMI	OMI adjustment enabled = Red
Controls	
AGC / MGC	AGC or MGC selection button
LASER ON / OFF	Laser (de)activation pushbutton
UP	OMI level UP pushbutton
DOWN	OMI level DOWN pushbutton
Test Points	
RF input at laser test point level (3)	17 dBmV per channel

Notes:

- (1) Only active in AGC mode.
- (2) Active in both AGC and MGC mode.
- (3) The value 17 dBmV is required to reach optimal OMI.

Specifications

RF Input		AGC / MGC	
Bandwidth	45-862 MHz	AGC via	Broadband detection
Level	18 dBmV \pm 3 dBmV	AGC pilot frequency	43.4 MHz
Impedance	75 ohm	AGC / MGC step	0.5 dB
Return loss	\geq 16 dB	AGC OMI adjustment range	-3 dB to +3 dB
Connector type	F	MGC OMI adjustment range	-10 dB to 0 dB
Optical Output		Power Requirements	
Wavelength	1310 nm (\pm 10 nm)	DC voltage	24 V
Laser type	DFBI laser diode	DC current	\cong 750 mA
Output power (4)	4/6/8/10/13/16/20/25/31 mW	Power consumption	18 W
Flatness	\pm 0.75 dB	Environmental	
Fiber type	monomode 9/125 μ m	Operating temperature	-10 to +50°C (14 to 122°F)
CSO	\leq -60 dB	Monitoring	
CTB	\leq -65 dB	Communication standard	RS-485
Carrier to noise ratio (5)	\geq 53 dB		
Optical isolation	\geq 30 dB		
Connector type (6)	FC/APC8°		

Notes:

- (4) To be defined when ordered.
- (5) Tested under the following conditions: receiver responsivity 0.85 A/W; receiver thermal noise 8 pA/Hz; 42 channels @ 18 dBmV; at 5 MHz noise bandwidth
CNR \geq 53 dB for lasers with output \leq 20 mW; CNR \geq 52 dB for lasers with output \geq 25 mW.

Optical Power (mW)	2-4	4-6	6-8	8-10	10-13	13-16	16-20	20-25
Fiber Length (km)	10	15	15	20	20	25	25	30
Total Loss (dB)	4	6	7	8	9	10	11	12
CNR (dB)	53	53	53	53	53	53	53	53

- (6) Standard FC/APC8°, other connector types available on demand.